



**COLORADO CITY METROPOLITAN DISTRICT
PUBLIC NOTICE
BOARD OF DIRECTORS STUDY SESSION**

A study session for the Board of Directors of the Colorado City Metropolitan District will be held Tuesday May 24, 2022, beginning at 6:00 p.m.

1. Payroll/HR with standards changing Got quotes
2. Pilot Test for DAF
3. CTF Funding Contract with PBCC Pool
4. Tap Fees
5. Leasing of property for grazing
6. Board Discussion of Direction of meeting Conduct and Demeanor
7. CCAAC Review

BOARD OF DIRECTORS REGULAR MEETING

A regular meeting of the Board of Directors of the Colorado City Metropolitan District will be held Tuesday May 24, 2022, beginning at 6:15 p.m.

1. CALL TO ORDER.
2. PLEDGE OF ALLEGIANCE.
3. MOMENT OF SILENT REFLECTION.
4. QUORUM CHECK
5. ELECTION OFFICERS CHAIRPERSON, CO-CHAIRPERSON, SECRETARY, TREASURER
6. APPROVAL OF AGENDA.
7. APPROVAL OF MINUTES.

Study Session May 10, 2022
Regular Meeting May 10, 2022
CCACC Minutes May 12, 19, 2022

8. BILLS PAYABLE.
9. FINANCIAL REPORT.
10. OPERATIONAL REPORT.
11. READING BY CHAIRPERSON OF THE STATEMENT OF CONDUCT AND DEMEANOR.
12. CITIZENS INPUT.
13. ATTORNEYS REPORT: Conflict of Interest, Rules of Conduct, and Ethical Principles
14. AGENDA ITEMS:

CTF Trust Fund Agreement

Payroll/HR

Pilot Test for DAF

Leasing of property for Grazing

Discussion/Action

Discussion/Action

Discussion/Action

Discussion/Action

15. OLD BUSINESS. Covenants Lawyer/Applewood Park/Cameras for plants/
Water Loss update/ Duell well

16. NEW BUSINESS:

17. CCACC:

A. New Construction

- | | | |
|----|--------------------------|-------|
| 1. | 5354 Trappers Trail | House |
| 2. | 1914 Beverly | House |
| 3. | 5880 Spotted Tail | House |
| 4. | 4631 Colorado Blvd | House |
| 5. | 5753 Lake Beckwith Drive | Fence |
| 6. | 1617 Griswall | Fence |
| 7. | 4200 Decker Place | Roof |

B. Actions

- a. 0 First Letters
- b. 0 Second letters
- c. 0 Third letters
- d. 0 Unauthorized Structure

18. CORRESPONDENCE. Letter

19. **EXECUTIVE SESSION:** 24-6-402(4)(b) C.R.S.Conference with water attorney for the public entity for the purpose of receiving legal advise on specific questions relating to water rights and legal issues surrounding lease agreements to rights.

20. ADJOURNMENT.

The meeting will be held at the Administration Building located at 4497 Bent Brothers Blvd., Colorado City, CO. 81019. Alternate location if so needed will be at the Recreation Center located at 5000 Cuerno Verde, Colorado City, CO. 81019.

Colorado City Metropolitan District

4497 Bent brothers Blvd

PO Box 20229

Colorado City, Colorado 81019

Posted May 20, 2022

James Eccher is inviting you to a scheduled Zoom meeting.

Topic: Colorado City Metropolitan District Study/meeting May 24, 2022

Time: May 24, 2022 06:00 PM Mountain Time (US and Canada)

Join Zoom Meeting

<https://us02web.zoom.us/j/89281295733?pwd=anVURzA0d1dYLzRadTlxbTJUeVh1UT09>

Meeting ID: 892 8129 5733

Passcode: 789552

One tap mobile

+13017158592,,89281295733#,,,,*789552# US (Washington DC)

+13126266799,,89281295733#,,,,*789552# US (Chicago)

Dial by your location

+1 301 715 8592 US (Washington DC)

+1 312 626 6799 US (Chicago)

+1 646 558 8656 US (New York)

+1 253 215 8782 US (Tacoma)

+1 346 248 7799 US (Houston)

+1 669 900 9128 US (San Jose)

Meeting ID: 892 8129 5733

Passcode: 789552

Find your local number: <https://us02web.zoom.us/j/kdr1AVNPd>



RUN POWERED BY ADP®

Proposal

For Colorado City Metropolitan District



05-06-2022

Colorado City Metropolitan District

Cpu Louis Guzzo Ent, CO 81019

Enclosed is the proposal outlining the ADP® services we discussed and other information you may find helpful. Your interest in ADP is greatly appreciated!

If you have any questions concerning this proposal or our solutions, please don't hesitate to contact me.

Best Regards,

John Legg
Elite District Manager
john.legg@adp.com



Solution Summary for Colorado City Metropolitan District:

Employees 20
Payroll Frequency Bi-Weekly

WHEN YOU CHOOSE ***RUN POWERED BY ADP®***, HERE'S WHAT YOU CAN EXPECT:

- Print your own checks or have them delivered
- Pay employees using ADPCheck™ or direct deposit
- Payroll in real time anytime, anywhere with secure online or mobile access
- Highly-skilled implementation specialists and both online and phone support
- Extensive online reports and general ledger exports to accounting software

Recommended Solution: **ADP Complete Payroll and HR Plus (Includes Zip Recruiter with 2 job slots)**



Per Payroll Cost: \$110.00**



One-Time Setup Fee: \$0.00

**In the event of additional jurisdictions, there will be a \$7 charge per month/jurisdiction.

Promotions

6680 - Months 4, 5, 6 and 7 FREE

Contact

John Legg
john.legg@adp.com
(585) 268-6729

*This is a Proposal only. Fees are estimates and are subject to change based on variation in payroll details, frequency, features, number of employees, etc. Additional fees may be incurred if other services are purchased or for additional tax filings including, but not limited to, additional states or 'applied for' statuses. Please consult with your sales representative for further details. The information contained in this proposal is confidential and proprietary and should not be shared with anyone outside your company.



Solution Detail for Colorado City Metropolitan District*:

Employees 20
 Payroll Frequency Bi-Weekly
 Start Date 05-13-2022

Payroll

- Payroll Processing
- Tax Filing
- Electronic Reports
- Employee Access
- ADP Mobile Payroll
- General Ledger Interface
- Pay Option: FSDD Only
- Delivery
- New Hire Reporting
- Pay Options
 - FSDD
 - TotalPay
 - Check Stuffing/Signing
- Poster Compliance Update Service
- General Ledger Interface
- Garnishment Payment Service
- State Unemployment Service

HR

- HR HelpDesk
- Zip Recruiter (includes 2 job slots, 500 resume views)
- Background Checks (25 per year)
- Employee Handbook Wizard
- HR Forms and Documents
- HR Compliance Updates and Training
- HR Tracking (includes Performance, Education and others)
- Document Vault
- New Hire Paperwork
- State and Federal Resources
- HR Checkups
- Tip of the Week
- Quarterly HR Newsletter
- HR Dictionary
- Employment Verification
- Lifemart

Processing Investment

Product	Billing Frequency	Per Processing Fee
ADP Complete Payroll and HR Plus (Includes Zip Recruiter with 2 job slots)	Bi-Weekly	\$110.00 **

**In the event of additional jurisdictions, there will be a \$7 charge per month/jurisdiction.

Annual W2 Fees

Y/E Information Stmt, W2 20 W2's	Annually	\$173.95
Base price (\$54.95) + Price per W2 (\$5.95)		
W-2 Delivery	Annually	\$13.95

Promotions

6680 - Months 4, 5, 6 and 7 FREE

Total Savings with Promos: \$953.33

*This is a Proposal only. Fees are estimates and are subject to change based on variation in payroll details, frequency, features, number of employees, etc. Additional fees may be incurred if other services are purchased or for additional tax filings including, but not limited to, additional states or 'applied for' statuses. Please consult with your sales representative for further details. The information contained in this proposal is confidential and proprietary and should not be shared with anyone outside your company.



ADP® Complete Payroll and HR Plus

Manage your cashflow and compliance...PLUS get the latest small business innovations to help manage your people

Small businesses are working harder just to stay in business these days. How you choose to manage your back-office burden can pull your focus away from reaching your business goals — or it can bring you closer to achieving them.

With ADP Complete Payroll and HR Plus you'll get the latest in ADP's HR innovations designed specifically for small businesses to help you meet your most challenging HR needs. Plus you'll get a powerful set of tools and resources to help you manage your cash flow and compliance risk. With better control over the administrative side of your business — what could you achieve?

Cash and compliance management solutions

- **Flexible Payroll Input Options** – Enter your data online, by phone, or even on-the-go with our mobile payroll app. Either way, you can be confident that your data is safe and secure.
 - **RUN & Done®** – Automate your payroll, for salaried staff and hourly employees with standard hours, using RUN & Done. Set it up once and we'll run your payroll until you tell us to make a change.
- **Employee Access** – Employees can manage their personal information and federal tax withholding, access payroll and tax history, as well as view available integrated products like time tracking, health benefits, retirement plans or company policies.
- **General Ledger Interface** – Export journal entries from ADP into QuickBooks®, Xero, Creative Solutions or a generic output file — without re-keying data.
- **Health Care Reform Page** – The Health Care Reform Page will provide you access to resources to help you stay on top of health care reform changes, help determine if you may be considered an "applicable large employer" and affected by the Shared Responsibility provision of the Affordable Care Act (ACA), and determine your eligibility for the Health Care Tax Credit.
- **Payroll Preview** – Preview payroll results before processing to help reduce errors.
- **New Hire Onboarding** – Add new employees with just a few basic pieces of information and employees can enter their personal info, direct deposit, emergency contacts and federal tax withholding.
- **Electronic Reports** – View, access, export and print over 15 different reports online.
 - **Custom Reporting** – Choose the fields to include and their order, sort the data within columns, set filters and selection criteria, preview, print, export to multiple file formats and save custom reports for future use.
- **Payment Options** – Choose from two ways to pay your employees:
 - **ADPCheck™** – The most secure paycheck in the industry, signed and sealed with 10 advanced fraud protection features.
 - **Full Service Direct Deposit** – The quickest way to pay your employees — on payday, pay is automatically deposited in each employee's account.
- **Tax Filing** – We'll calculate, deposit, file and reconcile your payroll taxes — and respond to inquiries from taxing agencies regarding the returns we file for you.
- **New Hire Reporting** – Helps protect your company from penalties due to mistakes or late filings.
- **New Hire Paperwork** – Quickly download state and federal new hire forms all in one convenient place.
- **Labor Law Poster Compliance Update Service** – We'll also enroll you in our Labor Law Poster Compliance Update Service to help you comply with these regulations.
- **Garnishment Payment Service** – A cost-effective, comprehensive solution that helps you manage your wage garnishment processing.
- **State Unemployment Insurance (SUI) Management** – Complete management of your state unemployment insurance, including processing unemployment claims and reviewing your account for erroneous charges. We'll also handle correspondence from each state in which you pay unemployment insurance. Business Maxims OSHA (Occupational Safety & Health Administration) Workplace Safety

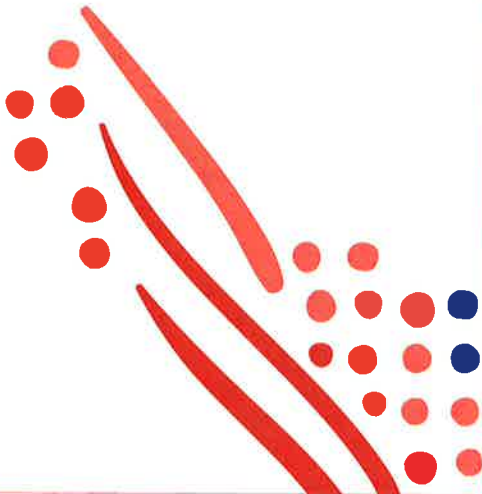

Always Designing
for People™

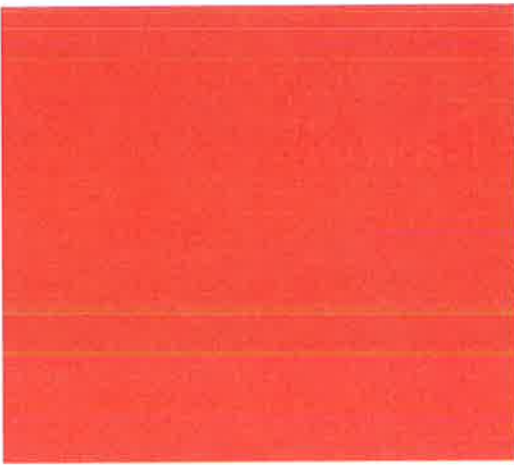

People management features designed for your business

HR technology.

- **Document Vault** – Eliminate paper and get centralized, searchable access to stored employee and company documents, as well as a library of HR bestpractice templates.
- **HR Tracking** – Get 24/7 access to HR pages that help you track employee information, such as assigned property and performance, and advanced reporting.
- **Alerts and Notifications** – Track important dates like employee anniversary dates, date of next performance reviews, and license and certification expiration dates. Use Company Notes to post reminders in one convenient location.
- **Job Description Wizard** – Create customized job descriptions based on an extensive database.
- **HR Toolkits** – Properly complete everyday HR and compliance responsibilities with step-by-step bestpractice guidelines, essential forms and documents, and related policies.
- **HR Forms & Documents** – Save time by obtaining your key HR forms from our central library of thousands of best-practice documents, checklists, forms and policies.

HR support, administration and compliance.

- **HR HelpDesk** – Receive phone and e-mail access to a dedicated support team of HR professionals to help you navigate even your most complicated HR issues.
- **Employee Handbook Wizard** – Create a comprehensive, professional quality employee handbook based on state and federal employment law in just a few simple steps.
- **Background Checks** – Includes SSN Validation*, 1 Criminal History Search** for the current county of residence, and ADP's CrimRadar™*** only. 25 free background check bundles included annually.
- **ADP® Employment Verification** – Helps you respond to employment and income verification requests when your employees apply for loans, lines of credit, or government benefits, freeing up time for you.
- **ZipRecruiter®** – Post jobs to 100+ job boards and social media sites in one click. Reach millions of job seekers with one post. Easily manage, screen and quickly identify top candidates – all in one place.
- **State and Federal Compliance Database and Compliance Updates** – Get information about ever-changing state and federal employment laws with plain English summaries of major regulations. Also receive proactive email alerts to help you stay on top of HR bestpractices and compliance requirements.
- **HR Checkups** – Compare your HR practices against standard HR best-practices in several key HR areas, with access to resources to help shore up your weaknesses.

HR information and education.

- **HR Fundamentals Training** – Self-paced online learning course covering various HR topics.
- **State and Federal Resources** – Help meet your core state and federal documentation requirements with convenient access to key government forms and documents.
- **Tip of the Week** – Receive practical how-to articles that provide best-practice information to complete your everyday employee management tasks.

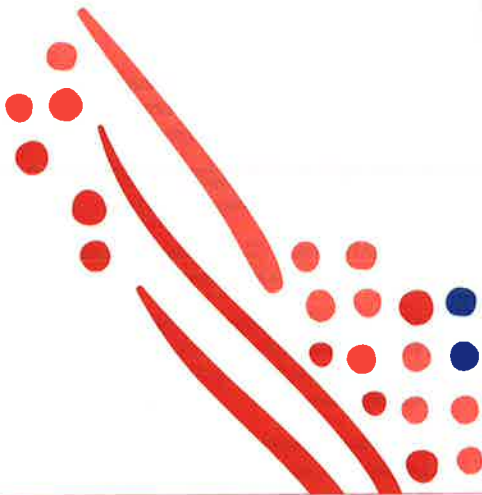

Always Designing
for People™

A la carte charges will apply to products ordered outside the background check bundle (example: verifications, driving records, registry searches, credit, other court records, etc.).

*Only confirms social security number was issued and number is not on the death master database.

** A \$65 state surcharge applies when ordering criminal searches from New York

ADP, the ADP logo, ALINE Card by ADP, RUN and Done and Always Designing for People are trademarks of ADP, Inc. ZipRecruiter is a registered trademark of ZipRecruiter, Inc. All other marks are the property of their respective owners. Copyright © 2019 ADP, Inc. All rights reserved.

Proposal for Services

HR Essentials



Prepared for:

CO City Metro District
James Eccher
Colorado City, CO 81019
colocitymanager@ghvalley.net

Prepared by:

Claudia Villani
Sales Representative - HR Services
cvillani@paychex.com
+1 3039099778

PAYCHEX[®]

HR | Payroll | Benefits | Insurance

Proposal Overview

On behalf of Paychex, I'd like to thank you for the opportunity to discuss your organizational needs and review how we may assist in helping you reach your business goals.

The following proposal addresses your organization's top business initiatives.

Your Business Initiatives

- Improve business outcomes with personalized HR support and effective recommendations.
- Stay on top of changing Federal & State regulations.
- Improve productivity by streamlining multiple systems into one integrated HR, Benefits & payroll platform.
- Develop a workforce that's engaged, driven, and contributing to organizational success.



Dedicated
HR Professional

I'm confident Paychex can help drive meaningful results for your organization given our **50+ year history of helping customers like you**. Please review the following information and feel free to contact me with any questions or feedback you may have.

I appreciate your consideration and I look forward to discussing next steps.

Claudia Villani

Your Custom Paychex Solution

Essential guidance to manage critical areas of running a business

Paychex HR Essentials is an affordable solution that delivers the most commonly requested human resource services for your business. A hallmark of our solution is access to an HR professional dedicated to your business to help answer questions about HR issues as well as federal and state employment laws.



Improve Business Outcomes with Personalized HR Support

- Count on a trusted process
 - HR Assessment
 - HR Action Plan
 - Quarterly Touch Points
- Gain insights & options for common HR issues

Reduce Business Risk & Increase Productivity

- Establish an HR infrastructure for an efficient, repeatable process
 - Transparent company policies with Employee Handbook Building
 - Online HR Library; Job Descriptions, E-forms, Salary Benchmarking
- Educate on Federal & State regulations
- Manage safety compliance with OSHA Safety assessment, programs, and training

Engage & Motivate Your Employees

- Best-in-class Learning Management System with more than 100 on-demand courses
- Support with professional development and career pathing
- EAP and Work Life Balance support including Wellness Programs, Legal Referrals, and Counseling Referrals
- Employee Discount Program

Next Level HR: Proactive | Qualified | Trusted

Your Dedicated HR Professional

Count on your dedicated HR professional to help improve business outcomes with personalized HR support including insights & options for HR issues



Trusted Process:

1. Help identify opportunities based on an in-depth **HR Assessment** and a clear understanding of your business
2. Develop an **HR Action Plan** tailored to your company's objectives and needs
3. Provide quarterly touch points

Average
7+ Years
Tenure*

Certified
HR Professionals*

+600
Nationwide

Unsurpassed Network of Knowledge within Paychex to Support You

Compliance

Paychex compliance professionals monitoring regulatory changes at the local, state, and federal levels

Safety

A dedicated safety professional for you to help build an OSHA-compliant program

* Your HR professional may have different credentials. Please consult with your Paychex Sales Representative for additional information.

Investment Summary

CO City Metro District

Created Date: 05-16-2022

Quote Number: Q-307371

Monthly Fees	Units	Rate / Unit	Total	Discount	Rate / Unit after Discount	Net Total
HR Essentials - Per Employee	25	\$3.00	\$75.00	0.0%	\$3.00	\$75.00
HR Essentials Base Admin Fee	1	\$175.00	\$175.00	10.0%	\$157.50	\$157.50
Total						\$232.50

One-time Fees	Units	Rate / Unit	Total	Discount	Rate / Unit after Discount	Net Total
Implementation Fee	1	\$1,500.00	\$1,500.00	50.0%	\$750.00	\$750.00
Total						\$750.00

DRAFT

Notations

Product / Billing

Totals displayed do not include sales tax where applicable.

Prices are subject to change with advance notice; promotions are excluded from change.

* Additional training content for Paychex Learning Product offering is purchased through the e-commerce tool site by authorized users.

First 5 employees are waived within the HR Essentials - Per Employee Fee. After 5 employees, each additional employee is charged at a rate of \$3 per employee per month.

Implementation

HR Solutions and PEO setup fees will be invoiced in equal monthly installments over the next 6 Months

Year-End Delivery

- **Note:** Please review your delivery method with your service provider before 12/31 to avoid additional charges.

Your Custom Paychex Solution - Details

Based on a review of your organization's initiatives and requirements, we recommend PaychexOne HR Essentials solution. Our solution provides essential dedicated HR support and services that can help with critical areas of running a business.

Employee Handbooks	<p>Build a robust, online employee handbook that meets your company's needs now and in the future.</p> <ul style="list-style-type: none">• Pre-developed content.• Intuitive navigation.• Legally reviewed federal and state policies with ongoing updates to reflect new legislation.• Easy customization and updating capabilities.
Online HR Library	<p>Save time researching answers to your most urgent HR questions. We offer access to 500 downloadable HR forms and letters, 800 job description templates, state and federal employment law information, and salary benchmarking tools.</p>
Safety Services	<p>Our OSHA and safety management experts will assist you in developing a safety program that meets OSHA requirements and helps protect your employees. You will receive:</p> <ul style="list-style-type: none">• Safety assessment to identify applicable OSHA requirements.• Safety manual specific to your business that meets OSHA regulations• Access to required safety trainings.• Ongoing expertise and support from a dedicated safety expert.
Learning Management System	<p>Gain access to a best-in-class learning management system that includes over 100 on demand courses accessible anytime, anywhere. This system also allows you to track and view learner transcripts, assign training, schedule live trainings and purchase trainings.</p>
NexGen EAP: Employee Assistance Program and Work/Life Balance	<p>Our EAP service provides confidential support to employees. Services include: counseling referral, wellness program, legal referral, personal assistant benefit, prescription drug card, and critical incident stress debriefing.</p>
Employee Discount Program	<p>Paychex has partnered with Working Advantage, LLC, to provide you and your employees with discounted products and services such as Broadway theater tickets, theme parks, movie rentals, and much more.</p>

*LMS is only available for Paychex Flex® payroll clients. Non payroll clients still have access to safety courses.

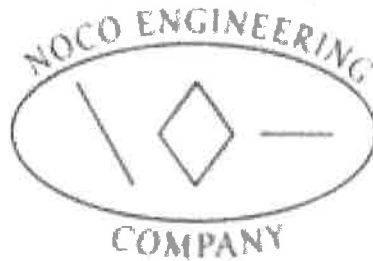

**NOCO Engineering Company (NEC)
Colorado City Metropolitan District (CCMD) Water Treatment
Dissolved-Air Flotation Pilot Plant Rental
AWC Reference No.: 42803 R1**

SUBMITTED BY:

9087A 198 Street
Langley, British Columbia V1M 3B1

Main Contact

Name: Ryan Harvey

Telephone: 604 364 2405

Email: ryanh@awcsolutions.com

Date: May 10, 2022





May 10, 2022

Attn: Josh Cook
Noco Engineering Company
257 Johnstown Center Drive #209
Johnstown, Colorado 80534

RE: AWC# 42803 – CCMD WTP – Dissolved-Air Flotation Pilot Plant Rental

Thank you for the opportunity to submit our proposal for the rental of our dissolved-air flotation (DAF) pilot plant. AWC is a world-leading manufacturer of DAF plants with over 15 high-rate DAF systems in operation around the world, and a combined total DAF installation base of 125 DAF systems. No other company offers the depth of experience and performance offered by AWC. Rev. 1 reduces the rental period to two weeks.

AWC provides complete industrial process solutions to a variety of industries. We focus exclusively on supplying and servicing equipment for industrial process that require worry free operation day-in and day-out. With a broad product offering and extensive in-house expertise, we offer our customers complete process control solutions for any application.

Located in Langley, BC, we employ the following disciplines, to provide a complete 'single-source' solution to any mechanical or electrical requirement:

- ↳ Technically competent and professional sales team
- ↳ Professional Engineers, to assist with process design
- ↳ Journeyman Technicians, to provide full start up/commissioning and maintenance/repair capabilities for everything we sell.
- ↳ CSA electrical panel shop for upgrades, modifications, or servicing providing full life cycle support
- ↳ Combined 65,000 sq. ft. facility providing mechanical and electrical repair and maintenance
- ↳ Full fabrication facility and machine shop, up to 20-ton lift capacity

With a full range of integrated services provided by highly experienced professionals, AWC is your one-stop-shop for modular turnkey industrial process solutions. We work extremely hard to provide our clients with unmatched service and provide the best total value and experience possible. We look forward to discussing how we can be of service to you.

Thank you for considering our proposal. If you have any questions, please do not hesitate to contact me at the coordinates below.

Sincerely,

A handwritten signature in black ink, appearing to read 'Ryan Harvey', with a long horizontal stroke extending to the right.

Ryan Harvey, Business Development Manager
604 364 2405 | ryanh@awcsolutions.com



TABLE OF CONTENTS

1	SCOPE OF SUPPLY	4
1.1	Dissolved-Air Flotation (DAF) Pilot Plant.....	4
1.2	Mobilization and Demobilization	4
1.3	Startup and Commissioning	5
2	Pilot Unit Availability	5
3	COMMERCIAL TERMS	5
3.1	Pricing Conditions	5
3.2	Currency	6
3.3	Quote Validity	6
3.4	Payment Terms.....	6
3.5	Terms and Conditions	7
3.6	Testing and Inspection Reports.....	7
3.7	Exclusions to the Scope of Supply	7
3.8	Shipping Terms.....	8
3.9	Schedule and Shipment	8
ATTACHMENT 1	DRAWINGS	9
ATTACHMENT 2	PILOT PICTURES	10
ATTACHMENT 3	OPERATIONS RATE SHEET	11
APPENDIX A	AWC TERMS AND CONDITIONS	12



1 SCOPE OF SUPPLY

1.1 Dissolved-Air Flotation (DAF) Pilot Plant

This DAF pilot is designed for a flow rate up to 40 gpm. The system comprises a feed pump, three chemical dosing pumps, one flocculation tank, one saturator system including recycle pumps, and one clarifier column.

AWC DAF Pilot

- Feed Pump, Inlet with isolation valve, magnetic flow meter, chemical injection ports, static mixer;
- Discharge pH and turbidity meters;
- Chemical dosing pumps;
- Adjustable two stage mechanical flocculation (VFD);
- DAF with inspection ports;
- Effluent tank with 1" discharge outlet and sampling ports;
- Lexan observation windows in the diffuser and DAF sections;
- DAF mechanical float skimmer
- Saturator and recycle pumps;
- DAF sampling ports;
- Manual drain ports for each section
- Control panel for electrical components.

The maximum plant design flow rate is 40 gpm, which equates to a clarifier loading rate of 30 m/hr (12 gpm/sf).

The total volume in the two flocculator mixing sections is 483 L (106 gallons).

Dimensions: 9'3" (L) x 5'6" (W) x 10'8" (H)

Empty weight: 3,500 lbs

The DAF skid has a control panel with an HMI screen. This provides the semi-automatic functioning of the DAF treatment. The power requirement for the panel and related equipment is - 125/250VAC 50A (L14-50R). The client can hardwire it or we can include an L14-50R plug. It also includes an emergency E-stop button for the DAF process.

1.2 Mobilization and Demobilization

It is understood that NEC and CCMD will arrange for transportation of the pilot from it's current location at the Carter Lake Filter Plant to the CCMD facility. So, in this case, mobilization simply includes one AWC technician on site. Client to provide electrician, mechanical and operations staff for tie-ins, installation, and system checks. Client shall also provide off-loading.

Client operator to run the pilot for the duration of the study.

Demobilization includes one AWC technician to assist with dismantling the equipment. Client to provide electrician, mechanical and operations staff for removal of tie-ins, draining of the tanks, equipment and piping, dismantling, and cleaning. Client shall also provide loading of equipment to AWC's carrier of choice. AWC shall



not be responsible for hauling of any waste materials. AWC staff shall work with site staff to remove the tie-ins to the AWC pilots in a safe manner. AWC shall confirm safe shut down of AWC equipment and complete an inspection report. Price includes two trips for one technician on site for five workdays total for both mobilization and demobilization.

Client shall be responsible for any make good costs incurred by AWC for any damage to pilot plants.

1.3 Startup and Commissioning

One AWC Operator will be on site for startup, commissioning, and training during the startup of the DAF. Any time in addition to that shown in the pricing shall be charged per our rate sheet. Power, communications, and tie-ins shall be completed by the Client prior to startup and Client shall provide an electrician to confirm all power supply is correctly installed. The startup team will verify that the tie-ins to the plant are correctly installed prior to startup. Price includes one trip, with a total of 3 workdays on site for startup and commissioning. All consumables, chemicals, utilities for the Pilot plants and waste disposal are not included.

Note that AWC has not included any allowance for hours for drawing preparation, sampling plans, pilot study report preparation. These items can be included upon request but will require additional charges.

Travel costs, board and lodging are to be charged per the field service rate sheet in Attachment 3.

2 Pilot Unit Availability

The pilot is available following the pilot study that is planned for Carter Lake. Once an approximate timeline is identified, AWC will review the operations calendar and indicate when we can have an operator on site for mobilization, start up and commissioning.

3 COMMERCIAL TERMS

AWC's commercial deliverables are provided below. If you have any questions, please do not hesitate to contact us.

3.1 Pricing Conditions

Pricing is subject to the acceptance of financial credit check of the client by AWC. Applicable taxes are not included. Pricing is based on AWC's standard Terms and Conditions and Warranty. Any deviations may result in price changes. AWC requires copies of specific project bonding.

Item#	Quantity	Equipment Description	Unit Price	Extended Price
1	2	AWC DAF Pilot Rental Considering noted clarifications & exceptions, AWC Terms and Conditions	\$2,250/week	\$4,500
2	1	*Freight back to AWC from site	\$15,000	\$15,000



Item#	Quantity	Equipment Description	Unit Price	Extended Price
3	1	Site services for Mob/Demob + Startup & Commissioning (5 days on site total included)	\$9,000	\$9,000
4	1	Travel + board & lodging are extra and will be charged at cost + 10%.	TBD	TBD
5	1	Additional days on site for startup, commissioning, support during the pilot, decommissioning etc. Travel (if required) + board & lodging are extra and will be charged at cost + 10%.	\$1000/Day	As required
Total:			\$ 28,500	

* Due to the current extreme volatility in freight rates, this is an estimate only. Price will be adjusted upward or downward based on actual cost + 10%.

Note that no allowance has been included for additional engineering, preparation of sampling plans, sampling and/or testing of water during piloting, or the preparation of a pilot report. These can be included upon request, at additional cost.

3.2 Currency

All pricing excludes taxes and is in US \$ currency.

3.3 Quote Validity

The pricing is valid for 30 days. However, availability for pilot plants and start-up personnel is on a first-come, first-serve basis.

3.4 Payment Terms

Payment milestones shall be as follows. All payments are due within 30 days of receipt of invoice.

1. Deposit: 25% of total due upon Notice to Proceed. To be held as a deposit, repayable at end of term, after AWC completes the demobilization inspection.
2. 50% of total due upon completion of Mobilization.
3. 50% of total due upon completion of Demobilization.
4. Freight, travel, field services, and accommodations (operator trip costs) to be billed following each trip.
5. Final payment (return freight, balance of operator trip costs) to be deducted from deposit, assuming no damage to units. Any unused deposit shall be returned to Client following inspection once received at AWC's Langley, BC facility.



Unit remains on rent until AWC is provided full and clear access to demobilize and remove the equipment.

Payment of invoices when due is of the essence and non-compliance constitutes a material breach of this agreement. At AWC's sole discretion, non-payment or late payment may result in suspension of performance of this agreement, holding shipment, modification of future payment terms, and/or any other action AWC deems necessary to protect its interests including termination of this agreement. Purchaser agrees to pay to AWC any additional costs incurred by AWC as a consequence of breach of this agreement.

3.5 Terms and Conditions

Except where otherwise set out in the Quotation, AWC standard terms and conditions as per Appendix A AWC Terms and Conditions shall apply.

3.6 Testing and Inspection Reports

The standard testing below shall be performed prior to shipping. Copies of AWC Test Procedures and Test Forms available upon request. Further testing and/or report requirements, including witness testing, is available at an additional cost.

3.7 Exclusions to the Scope of Supply

AWC scope of supply excludes the following items:

- No allowance has been included for additional engineering, preparation of sampling plans, sampling and/or testing of water during piloting, or the preparation of a pilot report. These can be included upon request, at an additional cost. Design, detailing of interconnecting pipework;
- Receiving, unloading and suitable storage of equipment;
- Loading of pilot plants for return to AWC;
- Pressure washing of tanks and equipment following shipment;
- Installation of all equipment supplied;
- Installation labour for process equipment;
- Operation of plant once it is commissioned by AWC personnel;
- Site preparation, foundation, building work;
- Piping connections, yard piping, drain piping, or other piping outside the tank, skid, or plant structures;
- Field electrical wiring and conduit;
- Controls and communication between AWC equipment and site equipment or any equipment supplied by Others;
- Re-termination of electrical wiring due to shipping constraints;
- Permitting;
- Any utilities or consumables such as power, water, waste management, chemicals, reagents, sampling, laboratory analysis, hose, chemical tubing, etc.;
- Client shall be responsible for maintenance costs and replacement of equipment due to wear and tear caused by use of the equipment;
- Client shall be responsible for damage to any equipment caused by improper operation of the system, or negligence by Others.



3.8 Shipping Terms

Outbound: NEC and CCMD to arrange for transportation from Carter Lake Filter Plant to the new piloting location and include insurance.

Inbound (return to AWC): Client responsible for (re)crating and loading. Freight and insurance cost by AWC, charged to Client at cost +10%.

3.9 Schedule and Shipment

The DAF pilot is currently available following the pilot study that is planned for Carter Lake. Once an approximate timeline is identified, AWC will review the operations calendar and indicate when we can have an operator on site for mobilization, start up and commissioning.

This schedule is based on AWC providing our standard pilot equipment. Any changes, drawing reviews or revisions if requested by the Client will extend the schedule.



ATTACHMENT 1 DRAWINGS

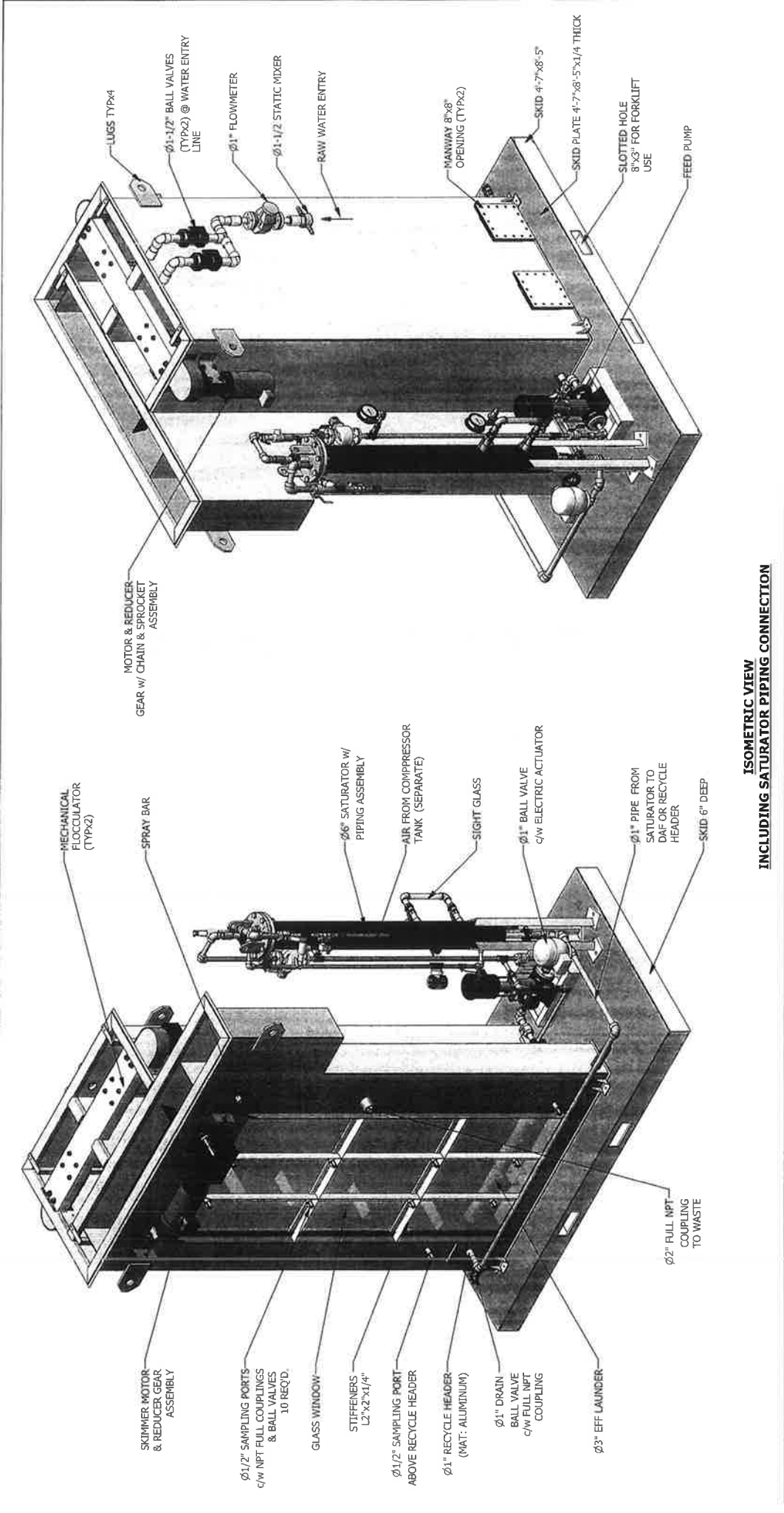

ISOMETRIC VIEW INCLUDING SATURATOR PIPING CONNECTION

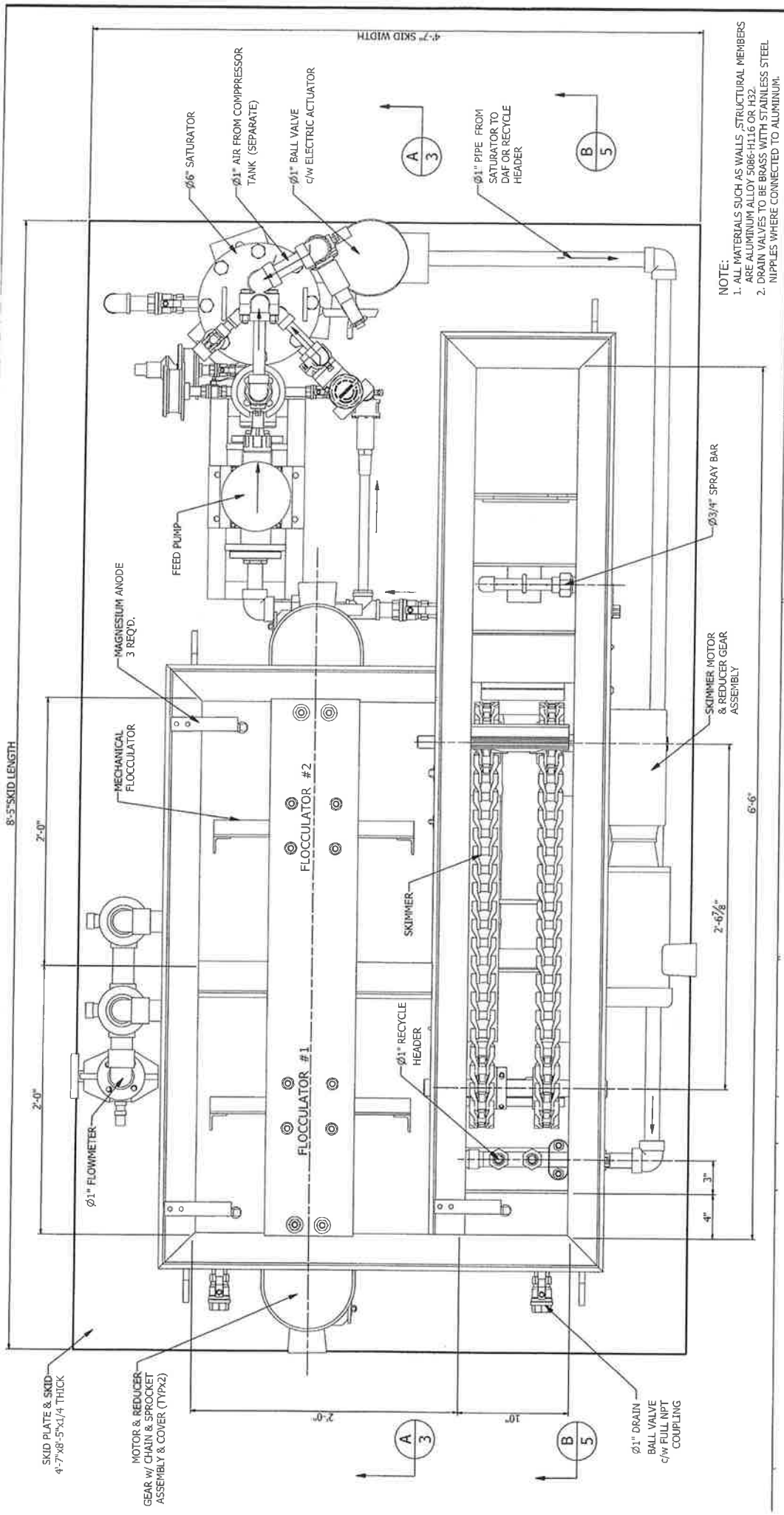

NOTE:
 1. ALL MATERIALS SUCH AS WALLS, STRUCTURAL MEMBERS ARE ALUMINUM ALLOY 5086-H116 OR H32
 2. DRAIN VALVES TO BE BRASS WITH STAINLESS STEEL NIPPLES WHERE CONNECTED TO ALUMINUM.

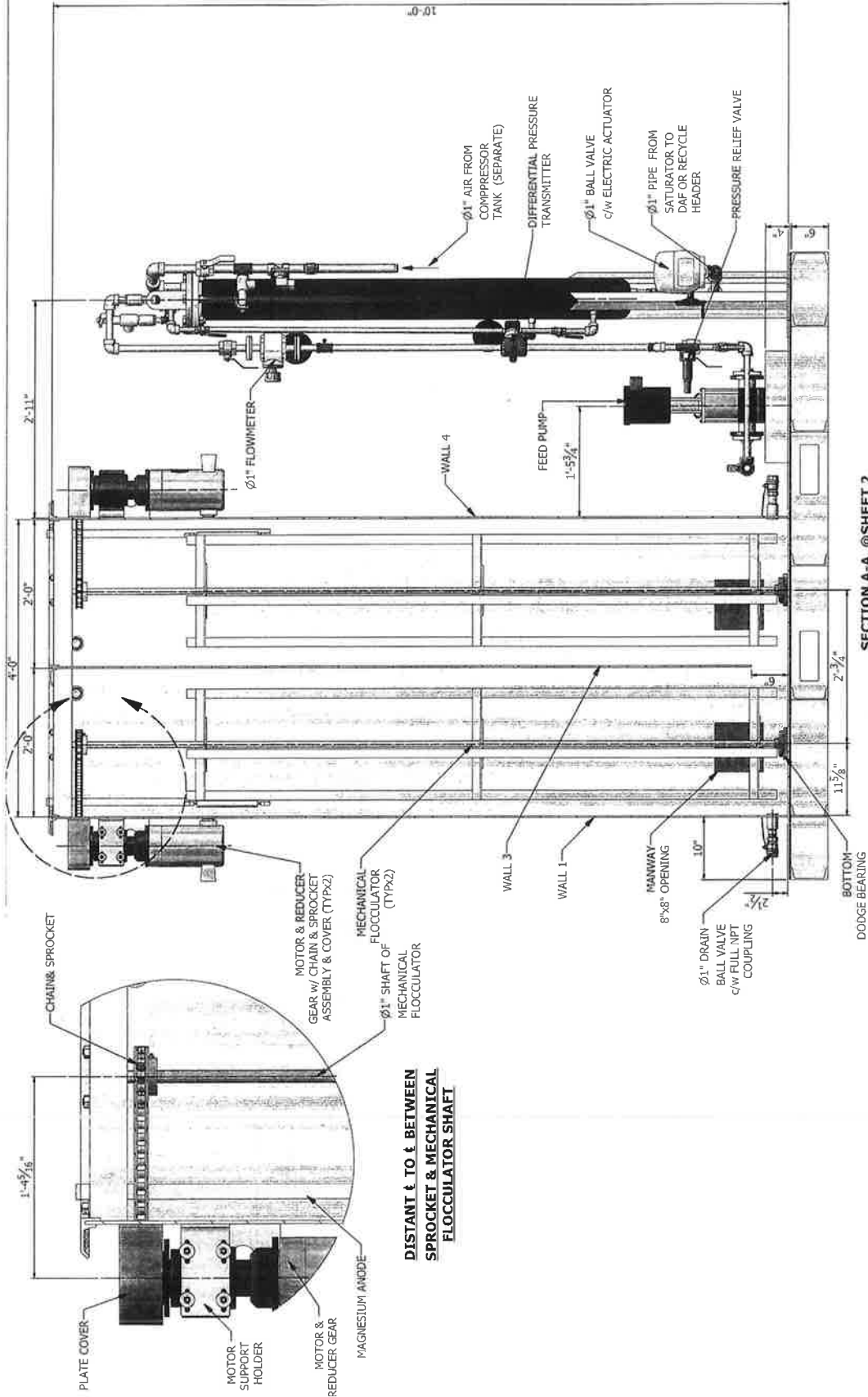

SECTION A-A @ SHEET 2

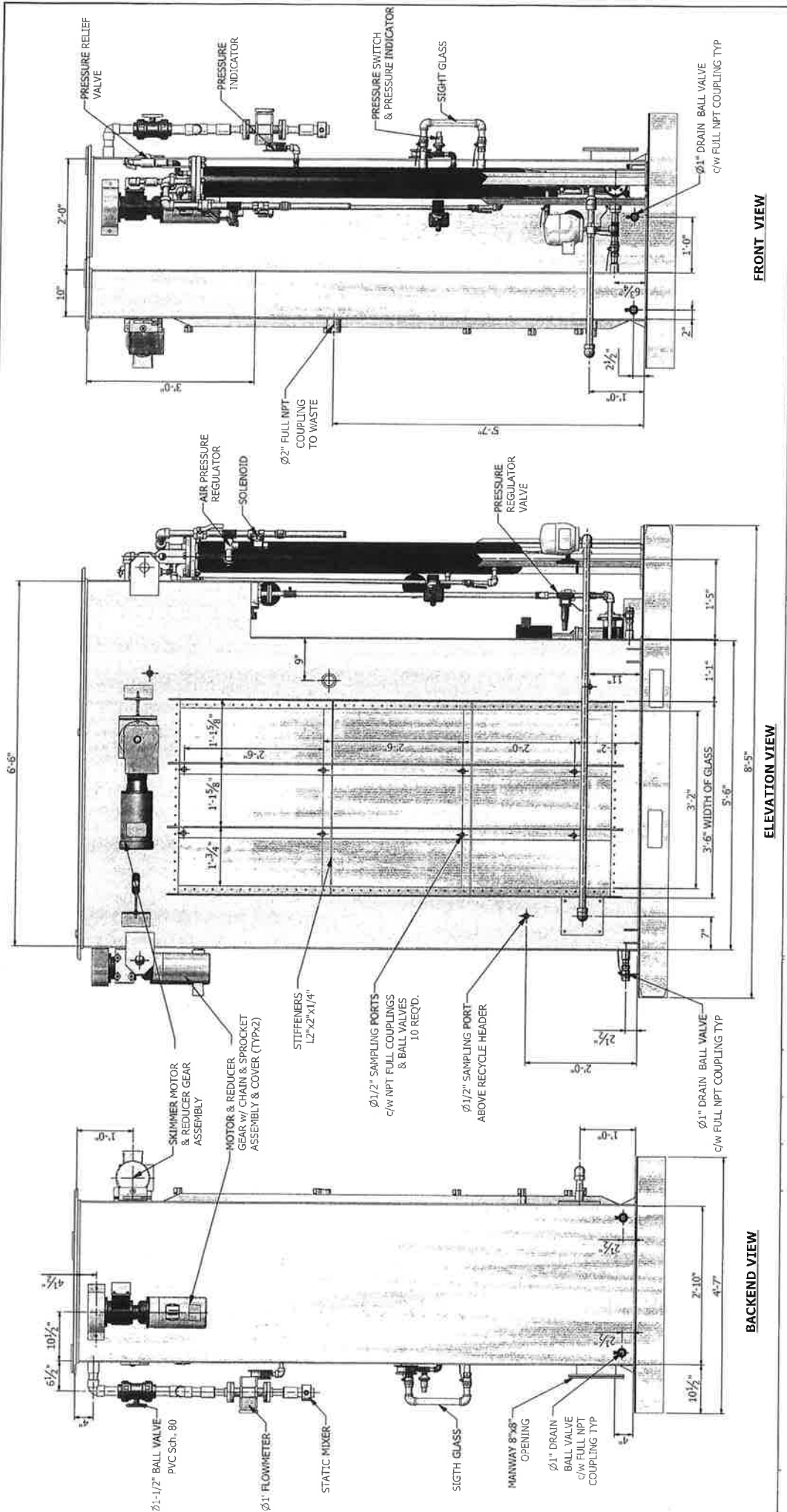

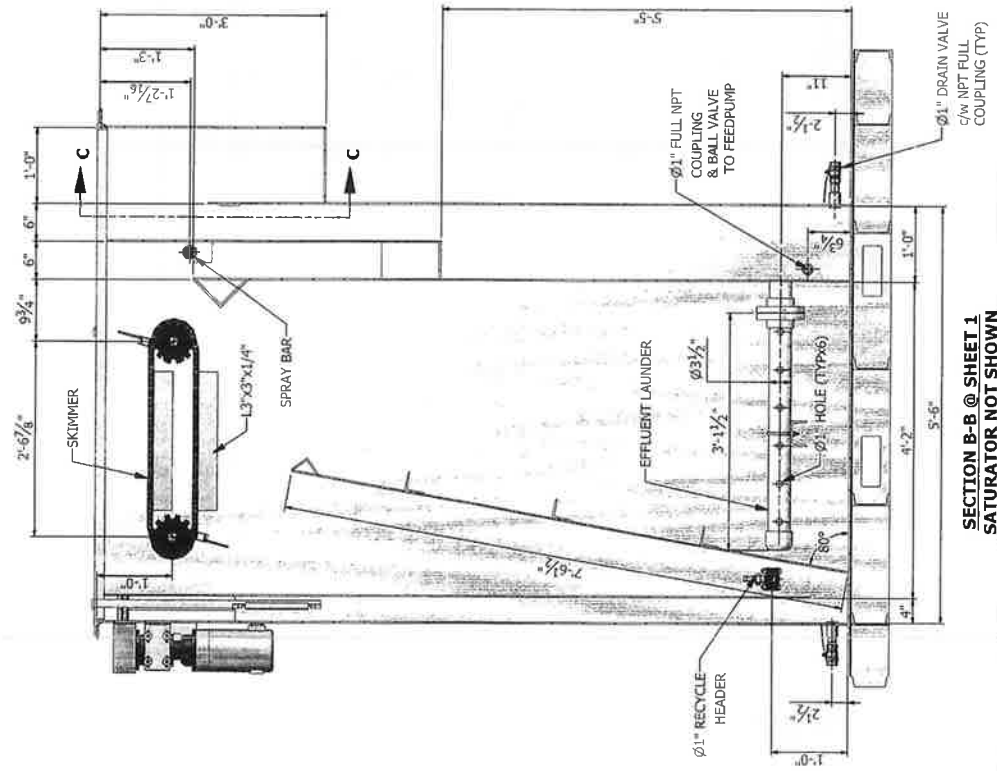

**SECTION B-B @ SHEET 1
SATURATOR NOT SHOWN**

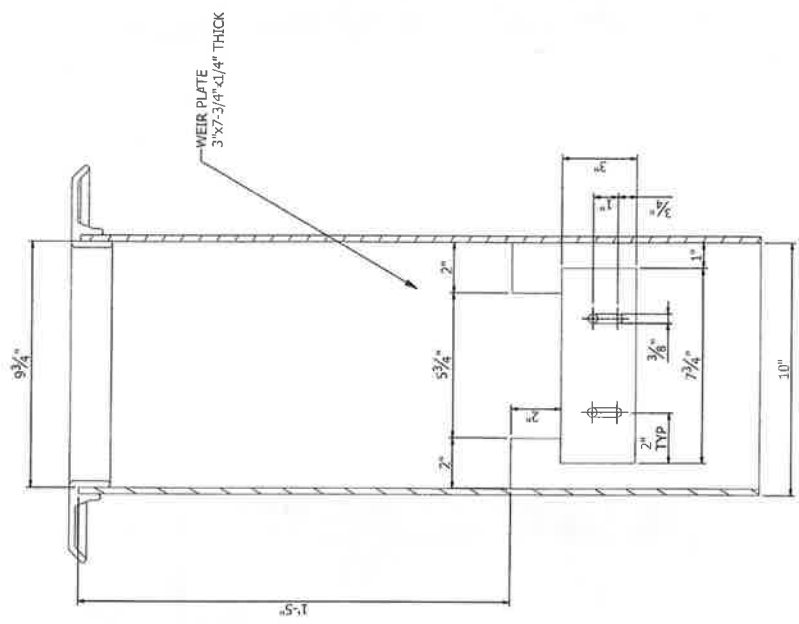

SECTION C-C

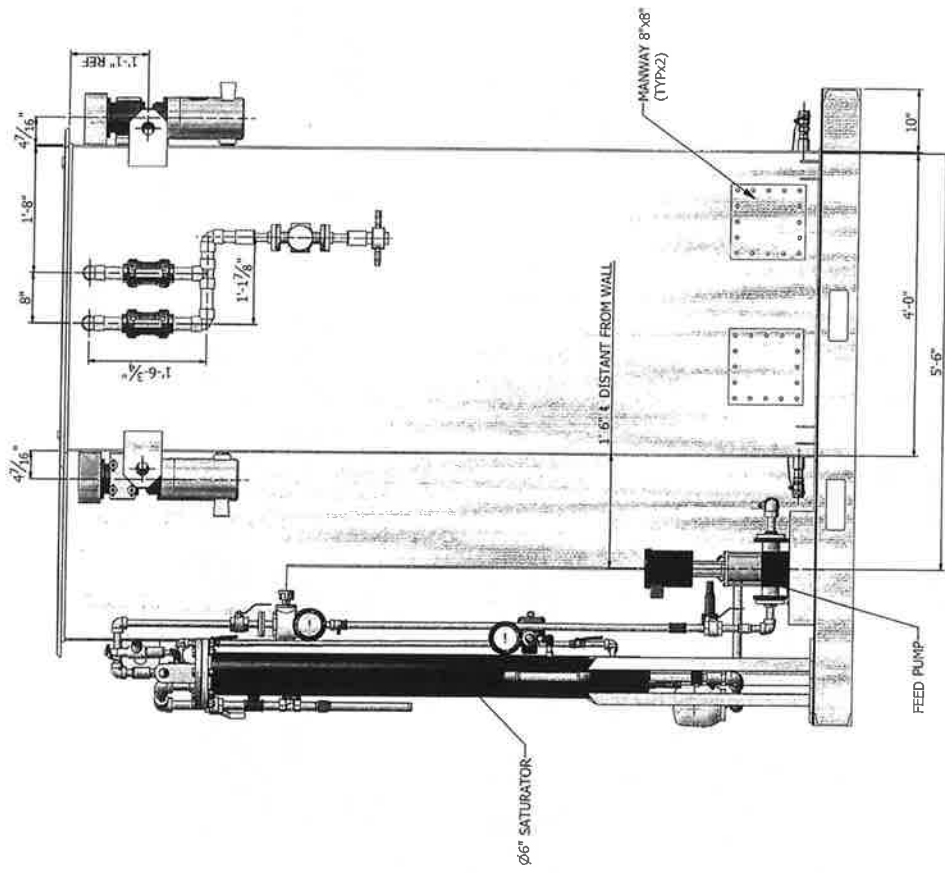

BACK VIEW

ATTACHMENT 2 PILOT PICTURES

DAF Pilot

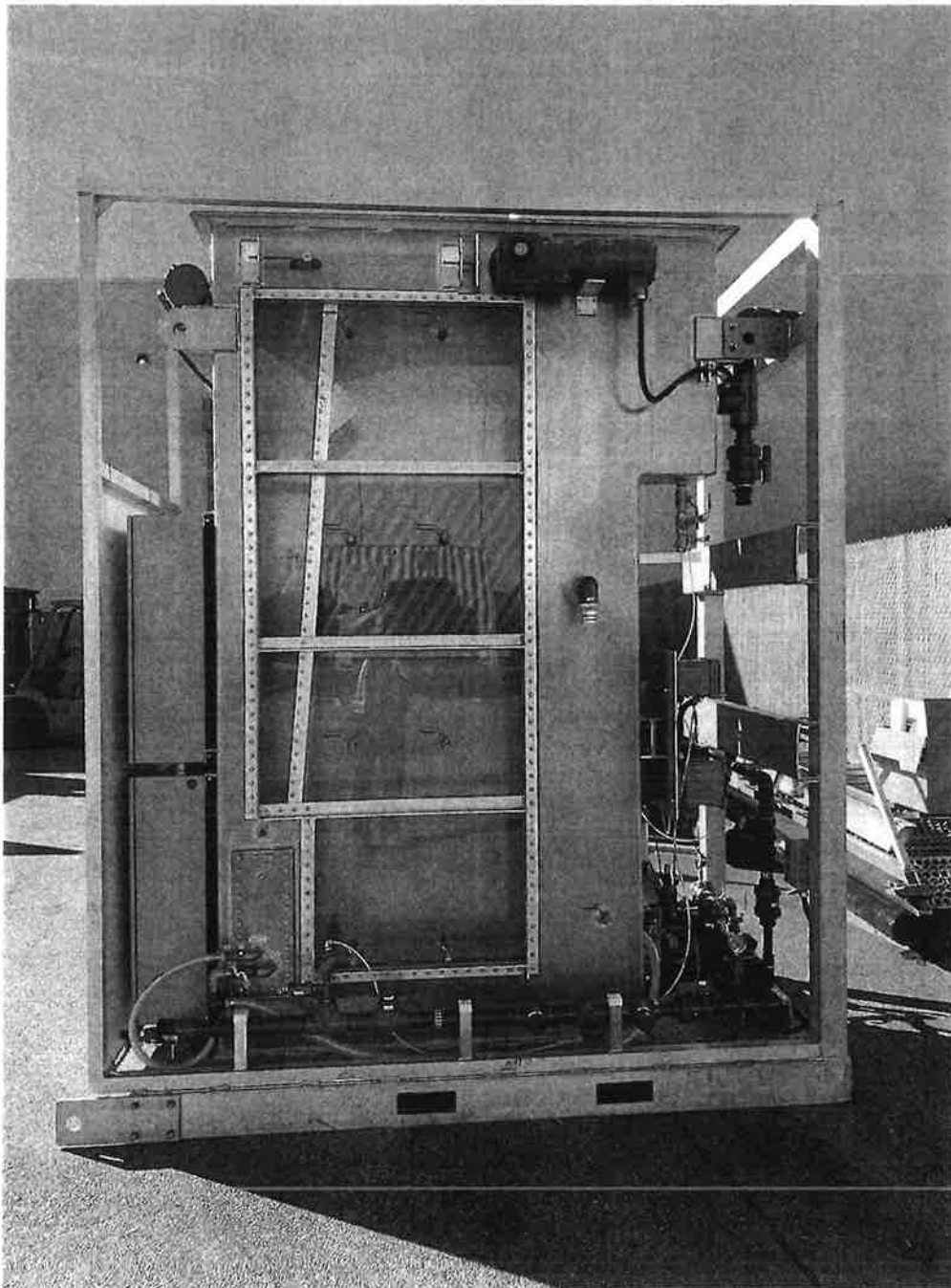



ATTACHMENT 3 OPERATIONS RATE SHEET



OPERATOR SITE SERVICES RATE SHEET

AWC's team of Level IV operators work closely with our technicians in the field. This significant reduces start the time it takes to start up, commission, and train. Our operators bring an enhanced level of support through a range of services such as plant operation contracts for the life of the plant, routine maintenance and membrane CIP support, ongoing training, monthly reviews, remote diagnostics and troubleshooting support.

Day Rate	\$1,100 per day
Hours	Max 10 Hours per day
Travel	Travel time is charged Day Rate Transportation charged at cost + 15%
Meals	\$85 per day
Accommodations	Cost + 15%

PRICES QUOTED IN CANADIAN FUNDS
RATES ARE PER OPERATOR
RATES ARE SUBJECT TO CHANGE WITHOUT NOTICE



9087A 198 Street
Langley, British Columbia, Canada
V1M 3B1



+1 (604) 936-4217



info@awcsolutions.com

www.awcsolutions.com



APPENDIX A AWC TERMS AND CONDITIONS

DEFINITIONS:

- i. **"Agreement"** means the Lessee's agreement to lease the Product(s) and/or Services from the Seller.
- ii. **"Lessee"** means the company, partnership, person, or entity leasing the Product(s) and/or Services from the Seller identified in the Documents.
- iii. **"Product(s)"** means the equipment parts and materials being purchased by the Lessee identified in the Purchase Documents.
- iv. **"Purchase Documents"** means the documents accompanying these Terms and Conditions which more fully describe the Products and/or Services being leased from the Seller, including, as applicable, the Lessee's request for quotation, purchase orders, and the Seller's quotation.
- v. **"AWC Solutions", "AWC" and "Seller"** means AWC Process Solutions Ltd or AWC Water Solutions Ltd.
- vi. **"Force Majeure"** means an event beyond reasonable control, including, without limitation, acts of God, earthquake, tsunami, storm, washout, landslide, avalanche or other extreme weather conditions, fire, flood, vandalism, explosions, strikes, lockouts or other industrial disturbances, unavailability of any goods, materials or equipment, acts of the Queen's or public enemies, wars, blockades, insurrections, riots, arrests, restraints or other civil disturbances, epidemics, restraints or prohibitions by any court or governmental board, department, commission or agency, and new or amended laws, and all other events of a similar nature.

2. APPLICATION: These terms and Conditions apply to every sale of Product(s) and every supply of Services by the Seller to the Lessee. The Lessee specifically agrees and acknowledges that unless the Seller agrees in writing to a modification of these Terms and Conditions, these Terms and Conditions apply and take precedence over any of the Lessee's Terms and Conditions whether set out in the Purchase Documents or otherwise.

3. PRICES: Unless otherwise specified by the Seller, the Seller's price for the sale of the Product(s) will remain in effect for forty-five (45) days from the date provided. The Seller's prices do not include applicable taxes which will be added to the price quoted and appear as a separate line item on the Seller's invoice. In case of any discrepancies between Lessee's Purchase Order and Seller's Order Confirmation it is the responsibility of Lessee to notify Seller within 24 hours of receiving the Seller's Order Confirmation after which point Lessee is bound to prices in Seller's Order Confirmation.

4. TERMS OF PAYMENT: Payment terms and schedule are of the essence. Subject to approval of the Seller's accounting department, the Lessee shall pay the Seller the price of the Product(s) and/or Services provided within thirty (30) days from the date of the Seller's invoice. If the Seller and the Lessee have agreed to a milestone payment schedule, the payment specified in the milestone payment schedule shall be paid on the dates that each milestone is achieved. All overdue payments bear interest commencing on the day on which the amount became payable, calculated at the rate of 1.2% per month compounded monthly (15.3895% per annum).

5. DELIVERY AND TRANSFER OF TITLE AND RISK: All delivery dates of the Product(s) and/or Services to be provided by the Seller are approximate only and are based on the Seller having received from the Lessee all information required by the Seller to provide the Product(s) and/or Services. Seller shall in good faith attempt to effect delivery by the date specified but shall not be responsible or liable for delays due to unexpected circumstances. In no event will Seller be liable for incidental or consequential damages resulting from failure to meet the specified or amended delivery dates. All Product(s) shall be delivered to the Lessee at the location indicated in the Purchase Documents, EX WORKS at the point of the manufacture of the Product(s). All risk of loss or damage to the Products while in transit shall be borne by the Lessee.

6. DOCUMENTATION: The Seller shall supply the Lessee with the documentation specified in the Seller's quotation. Any additional copies of the documentation or the supply of documentation on alternative media will be provided by the Seller to the Lessee at the Seller's price in effect at the time of the request.

7. INSTALLATION: The Lessee shall be responsible for transporting, receiving, storing, installing, starting up, and maintaining all Product(s). If requested, the Seller may, at its option, provide Services to assist the Lessee in the installation of the Product(s) at a price agreed upon between the Lessee and the Seller or at the rates set out in the Seller's published rate schedule at the time the Services are rendered.

8. EXCUSE OF PERFORMANCE: The Seller shall be excused from the performance of any term or condition of this sale or the provision of Services when and to the extent that the performance is delayed beyond its reasonable control including, without limitation to, acts of God, wars, riots, labour unrest, inability to obtain materials or components, explosions, accidents, governmental requests, laws, regulations, orders or actions. If such an event occurs, the delivery date and the price of the Product(s) and/or Services to be provided by the Seller may be revised by agreement made between the Lessee and the Seller or the Seller may at its option cancel the sale of the Product(s) or agreement to provide Services in which case the Lessee will pay the Seller any and all losses, damages, dismantling, restocking fees, and any other costs or expense incurred by the Seller arising from such a termination.

9. TERMINATION AND SUSPENSION: The Lessee may terminate or suspend its purchase of all the Product(s) and/or Services provided that it pays the Seller for any and all losses, dismantling, restocking fees and any other costs or expenses arising from such termination or suspension. The Seller shall have the right, in addition to any other remedy deemed necessary, to either terminate its agreement to sell the Product(s) or provide the Services or suspend further deliveries of the Product(s) or provision of the Services to the Lessee in the event the Lessee fails to make any payment required to be made to the Seller when due.

10. WARRANTY: Subject to the limitations of liability and remedies set out in Section 12, the Seller warrants its Product(s) and/or Services as follow:

Seller's Products: The Seller will, at its option, repair or replace any defects in material or workmanship in any Product(s) manufactured by the Seller which appear within the earlier of twelve (12) months from the date of initial installation of the Seller's Product(s) by the Lessee, or eighteen months from the date the Seller's Product(s) were delivered to the Lessee.

Re-Sale Products: The Product(s) manufactured by any third party (including the Seller's principals and their affiliated companies) provided by the Seller to the Lessee as the manufacturer's distributor shall be subject to the manufacturer's standard warranty. The Lessee agrees that the Seller shall have no liability for correcting any defect in the materials and workmanship in any re-sale Product(s) and that the Seller's only obligation is to make a reasonable commercial effort to assist the Lessee in making a warranty claim as against the manufacturer's standard warranty.

Services: Any Services supplied by the Seller, including component integration, device configuration, and the repair of Product(s) are warranted against defects in workmanship for a period of the earlier of ninety (90) days from the date of the installation of the Product(s) or one hundred and twenty (120) days from the date of the



delivery of the Product(s) to the Lessee. Any interpretative services provided by the Seller are not warranted wither as to the accuracy or correctness of any such interpretations or any recommendations made by the Seller based upon these interpretations.

On-Site Warranty Support: If the Buyer requires the Seller to provide any Services relating to any defect in the Product(s) and/or Services rendered or any warranty claim made by the Lessee in respect of the Product(s) and/or Services, including diagnosis, dismantling, and reinstallation of Product(s), at the Lessee's site, all costs of travel to and from the Lessee's site and of these Services shall be paid by the Lessee at the rates set out in the Seller's published rate schedule in effect at the time the Services are actually provided.

11. WARRANTY EXCLUSIONS:

- a) The Seller does not warrant the performance of any Product(s) and/or services provided by it to the extent that the actual operating or other conditions differ from the specifications or other data supplied by the Lessee for the purpose of selection of design of the Product(s) and/or Services to be provided by the Seller.
- b) This limited warranty shall not apply to any repair or replacement of Product(s) caused by abuse, accidental damage, misuse, improper installation, and improper application, corrosion or inadequate or improper preventative maintenance of the Product(s).
- c) Except as expressly provided herein, there are no other representations or warranties of any kind, express or implied, as to the merchantability, fitness for particular purpose, or any other matter with respect to the product (s) or services.

12. LIMITATION OF REMEDY AND LIABILITY: The Seller shall not be liable for any kind of consequential damages including loss of anticipated profits, loss of use of equipment or any associated equipment, the loss of product from the Lessee's facility(s) or the loss of capital however caused. The Lessee agrees that the Seller's sole and exclusive liability for all losses and damages arising out of or connected in any way with the Product(s) and/or Services provided by the Seller shall be limited to the repair, correction, or replacement of the Product(s) and/or Services in accordance with the terms of limited warranty set out in Section 10 herein. The Lessee further agrees that the Seller's total liability arising out or connected in any way with the provision of the Product(s) and/or Services is limited to the value of the Product(s) and/or Services provided by the Seller under this Agreement.

13. INDEMNITY: The Seller agrees to protect, defend, and indemnify the Lessee, its respective officers, directors, employees, and consultants from and against any and all claims, demands, losses, causes of action, liability and costs (including all legal costs and attorney fees) of every kind and nature arising out of or connected in any way with damage to property, person injury, or death of the Lessee's employees, or third parties alleged to have been caused by any act or omission of the Seller connected with the Product(s) and/or Services provided by the Seller. The Lessee agrees to protect, defend, and indemnify the Seller, its respective officers, directors, employees, and consultants from and against all claims, demands, losses, causes of action, liability and costs (including all legal costs and attorney fees) of every kind and nature arising out of or connected in any with damage to property, personal injury, or death of the Seller's employees, or third parties alleged to have been caused by any act or omission of the Lessee.

14. INSURANCE: The Lessee shall provide at its expense property damage insurance or "all risk" builder's risk insurance covering all its property on the basis of full replacement cost value without depreciation which will name the Seller and any manufacturer of the Product(s) as additional insureds with a waiver of subrogation against all insured parties thereunder.

15. GENERAL PROVISIONS:

- a) Lessee shall not assign its rights or obligations under this Agreement without Seller's prior written consent.
- b) There are no understandings, agreements, or representations, express or implied, not specified in this Agreement.
- c) No action, regardless of form, arising out of transactions under this Agreement, may be brought by either party more than two (2) years after the cause of action arose.
- d) This Agreement is formed and shall be construed, performed and enforced under the laws of the Province of British Columbia. Any suit, action, or proceeding arising out of or connected in any way with this agreement shall be brought in a Court of the Province of British Columbia which the parties shall have exclusive jurisdiction to hear and resolve such disputes, subject only to the parties agreeing to resolve such disputes through arbitration.

16. CANCELLATION, CHANGES, AND / OR DELAYS: In the event an order is cancelled; a cancellation charge shall be applied. Cancellation fees shall be at the sole discretion of AWC, and based upon on allocated or buy-in material's status and/or labor applied, as well as a reasonable amount to cover overhead and profit.

Changes to the scope of supply as described in the prevailing Purchase Order, after approval of drawings or release to manufacture shall be subject to a change-order charge and subsequent delivery delay. Where possible AWC shall endeavor to accommodate such changes, however AWC cannot be held responsible for Deliverables that may become affected as a result of such change/s, whether a charge is applicable or not.

In the event of a delay outside the control of AWC, and where substantial work or costs have been incurred by AWC, payment terms shall be adjusted to preserve AWC's initially projected cash position.

AWC shall not accept an order which contains a penalty clause for late delivery unless otherwise described in the quoted Bill of Materials. AWC shall not participate with or become partners in a project where a penalty for late/non-compliant delivery would constitute a financial back-charge or discount to the agreed upon order value. AWC will not accept back-charges or claims for late delivery whether directly or indirectly caused by AWC or its suppliers.

17. FORCE MAJEURE: Neither Party shall be liable for delay or failure in the performance of any of its obligations hereunder if such delay or failure is due to causes beyond its reasonable control, including, without limitation, acts of God, fires, earthquakes, strikes and labor disputes, acts of war, terrorism, civil unrest or intervention of any governmental authority ("Force Majeure"); provided, however, that the affected Party promptly notifies the other Party and further provided that the affected Party shall use its commercially reasonable efforts to avoid or remove such causes of non-performance and to mitigate the effect of such occurrence, and shall continue performance with the utmost dispatch whenever such causes are removed. When such circumstances arise, the Parties shall negotiate in good faith any modifications of the terms of this Agreement that may be necessary or appropriate in order to arrive at an equitable solution. Each Party shall bear its own costs and expenses incurred in connection with Force Majeure (including for any efforts to mitigate the effect or impact of the Force Majeure), and neither shall seek recovery of such costs or expenses from the other Party. Throughout any period of Force Majeure, the Party affected shall provide the other Party with regular status updates, including reasonable and non-binding predictions as to when the Force Majeure condition is likely to cease

**PUEBLO COUNTY
CONSERVATION TRUST FUND
FUNDING ASSISTANCE AGREEMENT**

This Agreement, entered into this 24 day of May , 2022, *nunc pro tunc* January 1, 2022, by and between the County of Pueblo, Colorado, for the use and benefit of the Office of Budget and Finance, (hereinafter referred to as the "County") and

**COLORADO CITY METROPOLITAN DISTRICT
PO Box 19390
Colorado City, CO 81019**

(hereinafter referred to as the "Contractor"):

WITNESSETH THAT:

WHEREAS, authority exists in the Law, and Funds have been budgeted, appropriated and otherwise made available for payment in Fund Number 217-450000-4723.73, Department Conservation Trust Fund Allocation; and,

WHEREAS, required approval, clearance and coordination has been accomplished from and with appropriate departments of the County; and

WHEREAS, the County has received a request for funding assistance from the Contractor and desires to engage the Contractor to render certain activities aimed at benefiting and enhancing the community; and

WHEREAS, the Contractor's proposed program and services are to be performed within the County's jurisdiction; and,

WHEREAS, the County has determined that it is in the best interest of the citizens of Pueblo County's to aid the Contractor's proposed program and services through funding assistance.

NOW, THEREFORE, in consideration of the mutual covenants and agreements herein contained, and subject to the terms and conditions hereinafter stated, it is hereby understood and agreed by the parties hereto as follows:

1. **PROJECT DESCRIPTION AND SCOPE OF SERVICES:** The Contractor agrees to provide the following activities or services in accordance with the 2022 Work Budget approved by the County. Scope of Services shall be attached hereto and incorporated herein Exhibit A.
 - A. **Program Services:** Contractor shall use the funds provided hereunder to Support costs associated with maintenance and replacement of plumbing

issues for the Colorado City Public Pool as well as the replacement of the boiler located in Colorado City, in accordance with the attached Scope of Services and Budget for 2022 incorporated herein as Exhibit A.

2. **TIME OF PERFORMANCE:** The services of the Contractor are to commence as soon as practicable after the execution of this Agreement and shall be undertaken and completed in such a manner and sequence as to assure their expeditious completion in the light of the purpose of this Agreement, but **in any event all of the services required hereunder shall be completed by December 31, 2022.**

3. **COMPENSATION AND METHOD OF PAYMENT:** As compensation for the performance of the Contractor hereunder, the County agrees to pay the Contractor for the services outlined in Section 1.A. the amount of **\$120,000**, said amount to be provided in accordance with actual costs associated with the services provided for in Section 1.A. above and the 2022 Work Plan. The funds will be provided through various payments in accordance with actual costs. Contractor is to submit to Pueblo County copies of bills or receipts that demand payment for services identified in Section 1.A. above. Pueblo County will make reimbursement payments of the total costs as identified above, up to a maximum compensation of **\$120,000, for all work accomplished within the Scope of Services by December 31, 2022. Requests for reimbursement must be made two weeks prior to the anticipated payment date.**

All payments hereunder following the initial payment shall be conditioned upon the Contractor's compliance with all of the terms and conditions of this Agreement, including the reporting requirements contained in Section 1 herein. The County may withhold funds under this Agreement if the County determines that the programs or facilities of the Contractor are not in compliance with the terms and conditions of this Agreement. Additionally, where the County is providing funds to the Contractor as part of a matching funds situation whereunder the Contractor is receiving funding from other governmental entities, the Contractor shall provide the County with proof that all other such entities have contributed their respective shares of matching funds prior to receiving payments from the County after the initial payment from the County.

4. **LIMITATION OF PARTICULAR FUNDS:** The parties hereto expressly recognize that the Contractor is to be paid, reimbursed, or otherwise compensated with Conservation Trust Fund (CTF) provided to the County from the State's Lottery Funds, for the purpose of contracting for the CTF services provided herein, and therefore, the Contractor expressly understands and agrees that all its rights, demands, and claims to compensation arising under this Contract are contingent upon receipt of such funds by the County from the State. In the event that such funds or any part thereof are not received by the County, the County may immediately terminate this Contract without further liability to the County beyond the CTF Funds actually received for services performed through that date.

5. **MAXIMUM COMPENSATION:** It is expressly understood and agreed that in no event will the total compensation to be paid hereunder exceed the maximum sum, stated in Section 3 above, for all the services required. Any expenses, costs or expenditures made or incurred by the Contractor beyond the stated maximum sum shall be the sole and exclusive responsibility of the Contractor.
6. **COMPLIANCE WITH LAWS AND REGULATIONS:** The Contractor shall comply with all applicable laws, rules, regulations, ordinances, and codes of the federal, state, and local governments, including but not limited to, internal revenue service laws, rules, and regulations, Title VII of the Civil Rights Act of 1964, the Fair Labor Standards Act, and the Americans With Disabilities Act, as amended, and Contractor also agrees to comply with the letter and spirit of the Colorado Antidiscrimination Act of 1957, as amended (24-34-402, C.R.S.), and any other applicable law representing discrimination and unfair employment regulations.
7. **INDEPENDENT CONTRACTOR:** The parties understand and agree that the Contractor shall, at all times during the term of this Agreement, be deemed an independent contractor and not an employee of the County, and shall be responsible for, and obligated to pay, all withholding taxes, social security, unemployment, worker's compensation, and/or other taxes and shall indemnify and hold the County harmless from and against any and all claims for the same period. Contractor acknowledges and agrees that all of its personnel are its employees only, and not employees or agents of the County for any purpose whatsoever, including for purposes of Worker's Compensation.
8. **ASSIGNMENT:** This Agreement is not assignable in whole or in part without the prior written consent of all parties hereto.
9. **INDEMNIFY AND HOLD HARMLESS PROVISION:** The Contractor agrees to indemnify and to hold the County and its agents harmless from any and all claims, suits, expenses, damages or other liabilities, including reasonable attorney fees and court costs arising out of damage or injury to persons or property caused or sustained by any person, persons, or entities as a result of any intentional or negligent act or omission by Contractor or failure of Contractor to perform this Agreement according to its terms. By requiring this right to indemnification, the County in no way waives or intends to waive the immunity protections provided to the County and its employees under the Colorado Governmental Immunity Act, C.R.S. § 24-10-101, *et seq.*
10. **MONITORING ACTIVITIES:** The County shall review the progress reports as delineated above for monitoring purposes. In addition, the County may require the Contractor to provide copies of other program progress or financial reports or documentation, including those reports or documentation that the Contractor may submit to other funding entities. The County may conduct other monitoring activities as necessary throughout the period of this Agreement to determine

program progress and for purposes of data base computation and/or program evaluation. Such monitoring activities may include, but not be limited to, receipt of Contractor's monthly Board meeting agenda, minutes, etc.; attendance at Contractor's Board meetings; and on-site visits, including access to all records and documentation maintained by the Contractor.

11. **AMENDMENTS:** This Agreement may be amended at any time by the parties hereto, provided such amendment be reduced to writing and executed by both parties to this Agreement. The Contractor shall submit copies of any revised Work Program and Budgets to the County during the period of this Agreement, and any changes to said Work Program or Budgets shall require an amendment pursuant to this Section 11.

12. **AUDIT REQUIREMENTS:** If the Contractor is a United Way agency or has received State or Federal grant funding during the current calendar or fiscal year, either through the County or otherwise, the Contractor agrees to have performed an audit delineating the use of funds received under this Agreement. Furthermore, if the Contractor has an audit prepared at any time and for any reason during the term of this Agreement, the Contractor shall provide the County with a copy of such audit. Finally, as a condition to receiving funds under this Agreement, the Contractor shall, if requested by the County, have performed an audit delineating the use of funds received under this Agreement. The requirements of such an audit shall be at the sole and exclusive discretion of the County. For purposes of this Agreement, the term "audit" shall mean an examination of the Contractor's financial statements prepared by an independent certified public accountant in accordance with generally accepted audit standards. The audit shall be due to the County within 180 days after the end of the term of this Agreement.

13. **TERMINATION AND/OR CANCELLATION OF AGREEMENT:**
 - A. Pueblo County may, upon thirty (30) days' written notice to the other party, cancel this Agreement for any reason without liability to the County.

 - B. If, through any cause, the Contractor shall fail to fulfill in a timely and proper manner its obligations under this Agreement, or if the Contractor shall violate any of the covenants, agreements or stipulations of this Agreement, the County shall thereupon have the right to terminate this Agreement for cause by giving written notice to the Contractor of such termination and specifying the effective date thereof, at least five (5) days before the effective date of such termination.

 - C. Notwithstanding the provisions of Sections A. and B. above, the Contractor shall not be relieved of liability to the County for any obligations to repay funds advanced under this Agreement or for any damages sustained by the County by virtue of any breach of the Agreement by the Contractor, and the County may withhold any payment to the Contractor for the purpose of

setoff until such time as the exact amount of damages due to the County from the Contractor is determined. In addition, upon receipt of any notice to terminate under this Section, any unexpended funds allocated or advanced to the Contractor by this Agreement shall be reverted to the County.

14. **TERM / TERMINATION:** This Agreement **shall commence on January 1, 2022,** and unless sooner terminated as provided herein, **shall automatically terminate on December 31, 2022.** The parties understand and agree that this Agreement is subject to the annual appropriation of funds for its continuance by the County and upon failure of the County to appropriate funds for this Agreement, said Agreement shall be automatically terminated without liability for termination to the County.
15. **SEVERABILITY:** To the extent that this Agreement may be executed and performance of the obligations of the parties may be accomplished within the intent of the Agreement, the terms of this Agreement are severable, and should any term or provision hereof be declared invalid or become inoperative for any reason, such invalidity or failure shall not affect the validity of any other term or provision hereof. The waiver of any breach of a term hereof shall not be construed as waiver of any other term.
16. **PROHIBITION ON PUBLIC CONTRACTS FOR SERVICES REGARDING EMPLOYMENT OF A WORKER WITHOUT AUTHORIZATION:** If Contractor has any employees or subcontractors, Contractor shall comply with the provisions of C.R.S. § 8-17.5-101, et seq. and this Contract. The Contractor shall not knowingly employ or contract with a worker without authorization to perform work under this Contract; or enter into a contract with a subcontractor that knowingly employs or contracts with a worker without authorization to perform work under this Contract.

By execution of this Contract, Contractor certifies that it does not knowingly employ or contract with a worker without authorization who will perform work under this Contract and that the Contractor will participate in either the Federal E-Verify Program or the Colorado Department of Labor & Employment's "Department Program" as identified in C.R.S. §§ 8-17.5-101(3.7) and (3.3), in order to confirm the eligibility of all employees who are newly hired for employment to perform work under this Contract.

- A. Contractor shall not:
 - (i) Knowingly employ or contract with a worker without authorization to perform work under this Contract; or
 - (ii) Enter into a contract with a subcontractor that fails to certify to Contractor that the subcontractor shall not knowingly employ or contract with a worker without authorization to perform work under this Contract.

- B. Contractor has confirmed the employment eligibility of all employees who are newly hired for employment to perform work under this Contract through participation in either the E-Verify Program or Department Program.
 - C. Contractor shall not use either the E-Verify Program or Department Program to undertake pre-employment screening of job applicants while this Contract is in effect.
 - D. If Contractor obtains actual knowledge that a subcontractor performing work under this Contract knowingly employs or contracts with a worker without authorization, Contractor shall:
 - (i) Notify the subcontractor and the County within three (3) days that the Contractor has actual knowledge that the subcontractor is employing or contracting with a worker without authorization; and
 - (ii) Terminate the subcontract with the subcontractor if within three (3) days of receiving the notice required pursuant to sub-paragraph (i) above, the subcontractor does not stop employing or contracting with the worker without authorization; except that Contractor shall not terminate the contract with the subcontractor if during such three (3) days, the subcontractor provides information to establish that the subcontractor has not knowingly employed or contracted with a worker without authorization.
 - E. Contractor shall comply with any reasonable request by the Colorado Department of Labor and Employment made in the course of an investigation that the Department is undertaking pursuant to the authority established in C.R.S. § 8-17.5-102(5).
 - F. If Contractor violates this provision of this Contract, the County may terminate this contract for breach of contract and the Contractor shall be liable for actual and consequential damages to the County as required by law.
 - G. The County will notify the Office of the Secretary of State if Contractor violates this provision of the Contract and the County terminates the Contract for such breach.
17. **NO THIRD PARTY BENEFICIARY: Enforcement of the terms and conditions of this Agreement, and all rights of action relating to such enforcement, shall be strictly reserved to the County and the Contractor, and nothing contained in this Agreement shall give or allow any claim or right of action by any other or third person under this Agreement. It is the express intention of the County and the Contractor that any person other than the County or the Contractor receiving services or benefits under this Agreement shall be deemed to be an incidental beneficiary only.**

18. **SURVIVAL OF CERTAIN CONTRACT TERMS:** Notwithstanding anything herein to the contrary, the parties understand and agree that all terms and conditions of this Contract and the exhibits and attachments hereto which may require continued performance or compliance beyond the termination date of the Contract shall survive such termination date and shall be enforceable by the County as provided herein in the event of such failure to perform or comply by the Contractor or by its subcontractors.

19. **MODIFICATION/WAIVER OF TERMS, APPLICABILITY OF LAWS:** This Agreement constitutes the entire agreement between the parties and supersedes all prior and contemporaneous agreements, representations, and understandings of the parties. No variation or modification of this Agreement, and no waiver of any of the Agreement's provisions or conditions, shall be binding unless made in writing and signed by duly authorized owners, principals, or officers of the Contractor and the County. This Agreement shall be governed by, and construed according to, the laws of the State of Colorado.

In Witness Whereof, the County and the Contractor have executed this Agreement as of the date first above written.

ATTEST:

PUEBLO COUNTY:

By _____
Clerk to the Board

By: _____
Chair, Board of County Commissioners

Date: _____

APPROVED AS TO CONTENT:

By _____
Director, Office of Budget and Finance

ATTEST:

By _____
Board Secretary

CONTRACTOR:
COLORADO CITY METROPOLITAN DISTRICT

By: _____
Chair, Board of Directors

Date: _____

By: _____
General Manager

Date: _____

ATTACHMENT "A"
2022 SCOPE OF SERVICES

AGENCY NAME: COLORADO CITY METRO DISTRICT

TOTAL COUNTY AWARD: \$ 120,000

PROGRAM / PROJECT NAME: Public Pool Colorado City

PUEBLO COUNTY FUNDS: \$ 120,000 (CTF)

Detailed Description and Cost estimate of Capital Projects to be supported with Pueblo County Funds.

Support costs associated with maintenance and replacement of plumbing issues for the Colorado City Public Pool as well as the replacement of the boiler.



**Colorado City Metropolitan District
5/23/2022
Tap Fees**

	Water	Sewer	Total
Walsenburg	¾" \$2500	\$2000	\$4500
Pueblo West	¾" \$20,372	\$4,886	\$25,258
	1" \$25,,258	\$7836	\$41,966
Pueblo BoWW	¾" \$6326.29		
	1" \$6,402.72		
Fowler	¾" \$4,000	\$4,000	\$8,000
Rocky Ford	¾" \$1,755	\$1000	\$2,755
	1" \$3,106		
La Junta	¾" \$1755	\$400	\$2,155
	1" \$3106		
Trinidad	¾" \$2,061	\$1,500	\$3,561
	1" \$5,711		

James Eccher
District Manager
Colorado City Metropolitan District



Colorado City Metropolitan District

I received a call on the 40 acres of property west of the gravel pit in Shadow Hills.

He is willing to maintain the fence, rent for \$400 a month for 4 to 5 months, will be grazing horses on the property 5 to 9 max on the property.

James Eccher
District Manager
Colorado City Metropolitan District

**COLORADO CITY METROPOLITAN DISTRICT
RESOLUTION NO. 06-2022
A RESOLUTION ESTABLISHING SIGNATURES ON A BANK ACCOUNT**

WHEREAS, it is in the best interests of the Colorado City Metropolitan District to provide adequate control over the District's bank accounts and to prudently manage the District's Cash and Investments.

WHEREAS, the Board of Directors have determined that it is in the best interest of its District to change signors on all accounts at Bank of the San Juans.

NOW, THEREFORE, BE IT RESOLVED BY THE BOARD OF DIRECTORS OF THE COLORADO CITY METROPOLITAN DISTRICT:

The following individuals be removed as signors on all accounts at Bank of the San Juans:

Robert Cook, Director

And, the following individuals be added as signors on all accounts at Bank of the San Juans:

Terry Kraus,
Harry Hochstetler,
Sarah Hunter,
Gregory Collins,
Neil Elliot,
Yvonne Barron, Finance Director
James P. Eccher, District Manager

PASSED AND APPROVED this 24th day of May, 2022

COLORADO CITY METROPOLITAN DISTRICT

By: _____
, Chairperson

ATTEST:

By: _____
, Secretary



**COLORADO CITY METROPOLITAN DISTRICT
PUBLIC NOTICE
BOARD OF DIRECTORS STUDY SESSION**

A study session for the Board of Directors of the Colorado City Metropolitan District will be held Tuesday, May 10, 2022, beginning at 6:00 p.m. Chairman Elliot calls the meeting to order at 6:05 pm.

1. Move Meeting to May 24

Jim is requesting the next Board meeting be moved due to the May 31st being right after a holiday weekend and CCMD being closed the Monday prior. Board Members did not have any thing to discuss and are on board with the change.

2. Dam Inspection Report

Dam inspection report was included in the packet. Tree is being moved and Jim is looking at getting it dug out tomorrow. Mr. Collins is looking for an explanation to why some of the items where not taken care of in a timely manner and why the Board was not made aware of some of these issues sooner. Manager Eccher shared that it had previously been provided to the Board at some time this past year. Mr. Collins reiterated that if the State is requesting something be done, he would like for us to be more on top of the situation. Mr. Hochstetler has suggested a check list be complied with a list of tasks, weekly, monthly, etc. Chairman Elliot is requesting that moving forward Manager Eccher needs to CC all of the Board Members moving forward.

3. Utility Director

Manager Eccher went over the financial aspects of the position and the job description. Mr. Cook had some questions about where the financial numbers came from. Mr. Collins, has asked hat the new position would work and report directly with the Board and in relation with the District Manager.

4. CCAAC Review

Chairman Elliot present 3 builds that are recommended for approval. There are also 5 first letters and 5 second letters that they are asking for approval to be sent. Chairman Elliot posed questions regarding Barndominiums, Conex, Volunteers, Letters, that are all an essential part of the committee. Some follow-up will need to be reviewed.

COLORADO CITY METROPOLITAN DISTRICT

Neil Elliot, Chairperson

ATTEST:

Harry Hochstetler, Treasure
Approved this 24th day of May 2022

These minutes are not verbatim to the meeting and should not be considered a complete record of all discussions during the meeting. For complete proceedings and statements, please refer to the video or audio recording of the meeting.

BOARD OF DIRECTORS REGULAR MEETING

A regular meeting of the Board of Directors of the Colorado City Metropolitan District will be held Tuesday May 10, 2022, beginning at 6:15 p.m. Chairman Elliot calls the meeting to order at 6:53 pm.

1. CALL TO ORDER.
2. PLEDGE OF ALLEGIANCE.
3. MOMENT OF SILENT REFLECTION.
4. QUORUM CHECK

Chairperson Neil Elliot
Secretary Greg Collins
Treasurer Harry Hochstetler
Director Bob Cook
Director Terry Kraus

Also in Attendance:
Jim Eccher, District Manager
Yvonne Barron, Finance Director
Greg Bailey/Gary Golladay Water & Sewer
Ayden Gillund Utilities
Josh Briggs, Parks, and Rec

5. APPROVAL OF AGENDA.
Mr. Hochstetler motions to approve the Agenda. MR. Collins seconds the motion. All Board Members are in favor. Motion passes to approve the Agenda.
6. APPROVAL OF MINUTES.
Study Session April 26, 2022
Regular Meeting April 26, 2022
CCACC Minutes May 5,2022
Mr. Hochstetler motion to approve the above Minutes. Mr. Kraus seconds the motion. All Board Members are in favor. Motion passes to approve the minutes.
7. BILLS PAYABLE.
Manager Eccher presented the there was no questions from the Board at this time. Chairman Elliot asked that the bills be paid.
8. FINANCIAL REPORT. April 2022
April 2022 Financial report was presented to the Board by Manager Eccher.
9. OPERATIONAL REPORT.
Manager Eccher presented all Operational Reports to the Board as provided in the Agenda packet.
10. READING BY CHAIRPERSON OF THE STATEMENT OF CONDUCT AND Demeanor.
11. CITIZENS INPUT.
Dennis Kahrs, shared with the Board that he has been driving around town looking for leaks on a volunteer basis and has not come across anything at this time. He has also been doing some research on nonprofit groups that come out and survey the area and can assist in finding possible leaks. He did share a website for Palmer Lnd.org. Mr. Kahrs also suggested of a community burn pile and shared his feelings regarding the Statement of Conduct and Demeanor.

Bill Cavanaugh presented questions about the post office and water costs. Chairman Elliot shared that he will Contact Mr. Cavanaugh directly for follow-up.

Ed Roland shared concerns about the water, restrictions and water taps. He also shared that he feels that the Web site should have more updated information for the Community to have access to.

Sharon Adams had questions regarding a road being put in at her residence as she can not get a straight answer from Pueblo County or she feels CCMD. Manager Eccher will contact her directly for follow-up.

12. ATTORNEYS REPORT. N/A

13. AGENDA ITEMS:

Utility Director

Discussion/Action

Mr. Collins motions to table the Utility Director position until the next meeting May 24, 2022. Mr. Hochstetler seconds the motion. Open for discussion. Mr. Cook weighed in that the position can be as is and the edits can be made but posting for the position should not be tabled at this time. Mr. Collins then withdraws his motion at time. Mr. Collins motions to approve the Utility Director position to post and begin taking applications and review the edits at the May 24th, 2022, meeting. Mr. Kraus seconds the motion. Open for discussion. Mr. Kraus does have concerns regarding the salary. It was shared that the salary that is being offered is at the minimum base pay. Chairman Elliot calls the vote. Mr. Cook yes. Mr. Collins yes. Mr. Kraus yes. Mr. Hochstetler yes. Chairman Elliot yes. Motion passes to approve the Utility Manager position.

Mr. Cook motions to move the next Board of Directors Meeting to May 24, 2022. Mr. Collins seconds the motion. There was no discussion. All Board Members are in favor. Motion passes.

14. OLD BUSINESS. **Covenants Lawyer:** Currently working with the PPMD. **Applewood Park:** We are Still at a standstill with gravel. **Cameras for plants:** Manager Eccher is getting ready to order, he is going to verify the resolution firsthand. A picture description was included in the packet or the Board to review. **Water Loss update:** This will continue to be a process or accuracy, but have already found multiple issues and resolutions. **Duell well:** Email as included from Richard Martinez for correspondence that we are scheduled for 2-3 weeks out at the time of this meeting.

15. NEW BUSINESS: N/A

16. CCACC: Questions to Board Barndominiums, Conex, Volunteers, Letters

A. New Construction

- | | |
|-------------------------|-------------|
| 1. 4760 Mosca Place | House |
| 2. 5851 Lakeview Circle | House |
| 3. 3166 Armstrong Ct. | Patio cover |

Mr. Collins motions to approve the 2 new homes and the patio cover as approved by CCACC. Mr. Kraus seconds the motion. Chairman Elliot calls the vote. Mr. Cook votes no. Mr. Collins votes yes. Mr. Kraus votes yes. Mr. Hochstetler votes yes. Chairman Elliot votes yes. Motion passes.

B. Actions

- a. 5 First Letters
- b. 5 Second letters
- c. 0 Third letters
- d. 0 Unauthorized Structure

Mr. Hochstetler motions to approve the 5 first letters and the 5 second letter be sent out as approved by CCACC. Mr. Kraus seconds the motion. Chairman Elliot calls the vote. Mr. Hochstetler yes. Mr. Kraus yes. Mr. Collins yes. Mr. Cook no. Chairman Elliot yes. Motion passes.

17. CORRESPONDENCE. Letter Pickleball Players
Manager Eccher presented the letter to the Board as included in the packet.

18. EXECUTIVE SESSION: N/A

19. ADJOURNMENT.

Mr. Hochstetler motions to adjourn the meeting. Mr. Collins seconds the motion. Chairman Elliot adjourns the meeting at 8:07pm.

COLORADO CITY METROPOLITAN DISTRICT

Neil Elliot, Chairperson

ATTEST:

Harry Hochstetler, Treasure
Approved this 24th day of May 2022

These minutes are not verbatim to the meeting and should not be considered a complete record of all discussions during the meeting. For complete proceedings and statements, please refer to the video or audio recording of the meeting.

Del Olivas
Pueblo County Treasurer
215 w. 10 St. Room 110
Pueblo , CO 81003-2935

Colorado City Metropolitan Committee
P.O. Box 20229
Colorado City, CO 81809

Gentlemen,

My wife, Phyllis and I have owned Lot 462, Unit 9 in Colorado City since July 5th 1969. We were both born in Colorado and I was in the USAF. We bought the lot hoping it would appreciate and we could build our retirement home on it. We wanted a piece of our "home state".

We continued to pay fees, taxes, etc. for 53 years, partially because they were low. Then this year's evaluation lept from \$81 to \$4,500. (I wrote a letter to Frank Beltrand discussing my estonishment and disgust at the steep rise), We are both now 87 years old and know we will never build on this property. We can't even give it to any family or friends. Over the years, we had some offers with ranged up to \$1,200, but that was years ago.

Is there some way we can dispose of the propery to an orgnization in Colorado City , at no cost, to cut our ownership and tax responsibility? We are sure you have heard many stories similiar to ours.It was a big disappointment for a great many years and turned out to be a very poor investment,

Sincerely yours,

Jerry and Phyllis Stroh
3242 Lochwood Dr.
Fort Collins, CO 80525-2935
pnjstroh@comcast.net
ph. 970 223-6813

colocitymanager@ghvalley.net

From: JERRY D STROH <pnjstroh@comcast.net>
Sent: Saturday, May 21, 2022 11:00 AM
To: colocitymanager@ghvalley.net
Subject: Colo City Lot 462 Unit 9

Mr. James P. Eccher---Thank you for your quick response to my letter. We do not expect any payment for our lot. If the Metropolitan District is willing to take the lot off our hands, that is all we expect. What is done with the lot is not our concern as long as our names are removed from the owner's list so we are not responsible for taxes. Current taxes are up to date.

Since I sent the same original letter to Mr. Olivas, Pueblo County Treasurer, I sent him another letter informing him that I will be working with you and his services are not needed.

If you need more information to accomplish this task , kindly let me know.

Thank you for your interest,
Jerry Stroh